

TRUE-PIVOT™

P/N #20-19L

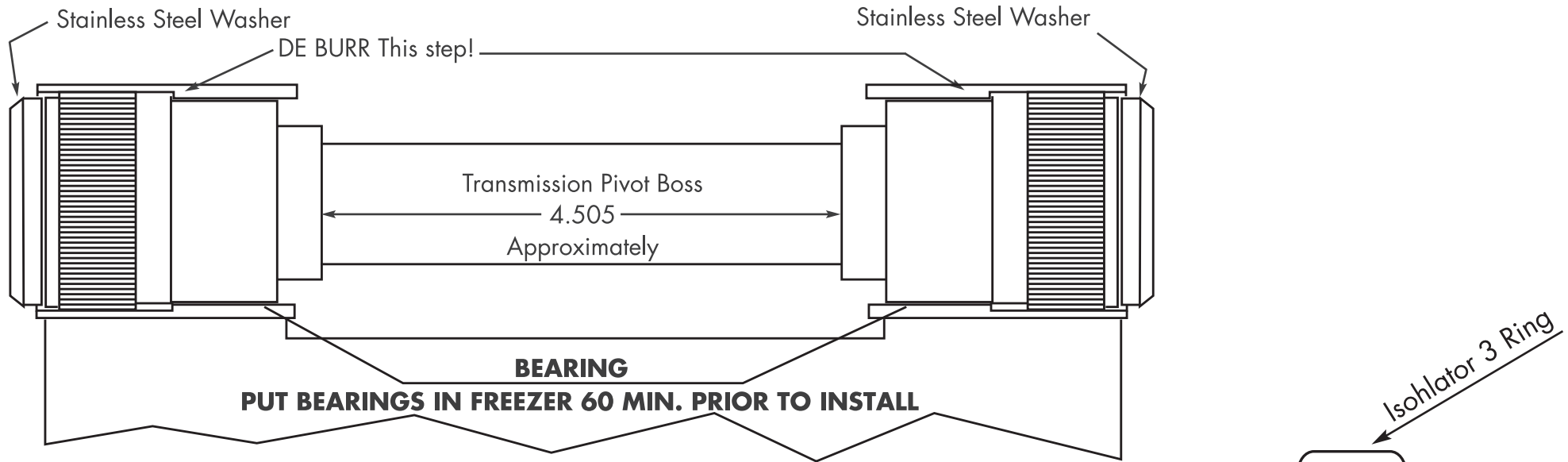

FOLLOW 2002-2008 Service Manual - EXPERIENCED TECHNICIAN REQUIRED FOR INSTALLATION

- 1. Remember to put bushings in the freezer before attempting installation for at least an hour. Blue loctite is to be used for lubricant and locking nuts on thread.**
2. Press out the Spherical Bearings. THE SPACERS ARE NO LONGER REQUIRED!
3. De-burr the step of the machined interior bore. Clean the bore with SCOTCH BRIGHT.
4. Apply WD-40 to bore.
5. Press in TRUE-PIVOT from the outside in. Each side must have equal distance and slide over the transboss.
6. Apply a liberal amount of ANTI-SEIZE in the swing arm bore to install the bushings.
- 6A. Press in TRUE-PIVOT. Each side must have equal distance and slide over the transboss.
7. Apply a liberal amount of marine grease to the shaft and in the groove on the inside of the bearing at each end.
8. Snug both sides up.
- 9. Do not tighten nuts to spec until the bike is sitting on the ground at ride height.**

